

Chapter 15

Urban Roads

Accessible Standard

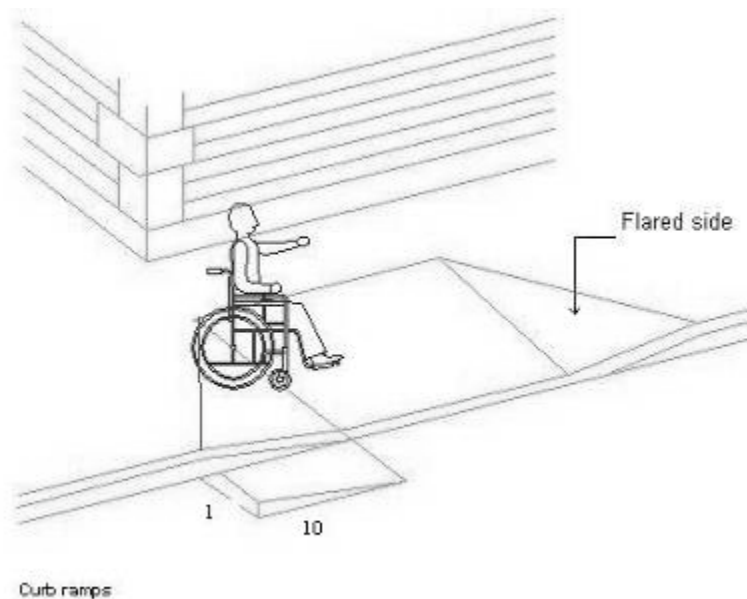

(15.1) PLANNING PRINCIPLE

To construct roads in the urban settings that enable all users especially blind persons and persons with mobility difficulties to use them without any difficulty.

(15.2) CURB RAMPS

Curb ramps are used whenever there is a difference in level on pedestrian paths or between sidewalks and road surface at pedestrian crossings, parking areas, bus-stops or in front of building entrances.

The minimum width of the curb ramp should be 0.9m between two flared sides of minimum width of 1.20m.

Curb ramps should be gently sloping with the minimum slope at a ratio of 1.20 or 1.10 for short curbs and maximum slope of the flare should be 1.10.

There should be curb ramps whenever there is a public building along the road to ease access from the main road to the building entrance by a wheelchair user.

Curb ramps should be made of non-slippery materials.

At zebra/pedestrian crossings, curb ramps should be provided at both sides of the crossing.

(15.3) KERB STONES

At points where pathways are specifically designed to cross roads with heavy traffic, kerb stones should be avoided.

If they cannot be avoided, distant-placed kerbs with maximum height of 40mm should be used to enable the blind person to recognize the pavements.

Kerb stones should be painted in contrasting colours for easy identification by blind persons or persons with visual impairment.

Lower kerbs should be placed at points where pedestrians cross the road to enable wheelchair users cross the road without any obstructions.

(15.4) PATHWAY

The minimum width of an un-obstructed pathway adjacent to the road should be 0.9m and preferably 1.5m.

Pathways should be even, gently sloping and connected to the road by the curb ramp. This eases access to the pathway by wheelchair users.

The surface of an accessible pathway should be smooth, continuous, firm and non-slippery.

The pathway should be given a different texture

Chapter 15

Urban Roads

Accessible Standard

and colour finish for differentiation from the main road.

Pathways should be filled with tactile clues like Braille blocks as route finders for the blind.

It is important to define clearly the edge of the pathway or routes by using different colours and textures.

(15.5) SAFETY

Roads near or adjacent to an institution or facility serving PWDs should be fitted with both a hump and a zebra crossing, with a hump preceding the zebra crossing to slow down speeding vehicles.

Zebra crossings should be well connected to the pathway without any inconvenience and accessible to every road user.

Roads should have enough road signs to effectively guide the road user including PWDs.

There should be audio signals in addition to traffic lights to alert the visually impaired pedestrians to cross safely.

(15.6) STAGE

This refers to the designated stages of either buses or taxis for passenger boarding.

a. Design

At least one accessible route of 0.90m wide and gentle gradient of 1:10 should be provided from the boarding point of the bus stop to the sidewalk or main accessible pathway.

Curbs should be provided along the accessible path from the boarding point to the accessible pathway or to accessible entrance of the building.

b. Location

Stages should be positioned strategically to enable a wheelchair user approach it without any difficulty.

Whenever there is a difference in level between the drop-off area of the bus and the sidewalks or pathway, a curb ramp should be provided.

c. Shelter

A shelter should be provided at the bus stand for protection against rainy and sunny weather conditions.

Seats should be provided at the stages for people with reduced mobility.

The seat should be positioned with enough free space to allow easy movement of wheelchair users.

d. Information

Clear information on the bus numbers and names of all bus stops should be indicated on the stage area.

This information should be in large print, contrasting colour and well illuminated at night.